

Weller®

HAP 1

- Ⓚ Betriebsanleitung
- Ⓛ Manuel d'Utilisation
- Ⓜ Istruzioni per l'uso
- ⓐ Operating Instruction
- Ⓡ Kullanma Kılavuzu

 **COOPER** Hand Tools

Beschreibung

D

100 W Heißluftkolben mit integriertem Fingerschalter, eignet sich zum Löten und Entlöten von oberflächenmontierten Bauelementen. Ein breites Düsenprogramm macht ihn universell einsetzbar.

Durch den im Handgriff integrierten Fingerschalter wird der Luftdurchfluß gesteuert. Die ausströmende Heißluft ist frei von statischen Ladungen. Schlauch und Handgriff sind anti-statisch ausgeführt. Die temperaturgeregelte Heißluft kann mit dem verwendeten Steuergerät zwischen 50°C und 550°C eingestellt werden.

Technische Daten:

Heizleistung:	100 W
Heizspannung:	24 V AC
Max. Luftmenge:	10 l / min.
Temperaturbereich:	50°C – 550°C
Genauigkeit:	+/- 30 °C

Inbetriebnahme

Sicherstellen, daß sich das Steuergerät im ausgeschalteten Zustand befindet. Den Heißluftpencil in der Sicherheitsablage ablegen. Den elektrischen Anschlußstecker in die 7 pol. Anschlußbuchse des Steuergerätes einstecken und verriegeln. Die Schlauchleitung auf den "AIR" Nippel des Steuergerätes schieben. Gerät einschalten und Temperatur und Luftmenge einstellen.

Achtung: Den Heißluftkolben nicht auf Personen oder brennbare Gegenstände richten. Nicht benützter Heißluftkolben stets in der Originalablage ablegen.

Potentialausgleich

Der Heißluftkolben ist mit einer Potentialausgleichsleitung ausgestattet die nach der Betriebsanleitung des verwendeten Steuergerätes beschaltet werden kann.

Löttechnische Hinweise

Die Heißluftdüsen sind in den Heizkörper eingeschraubt. Zum Düsenwechsel den Steckschlüssel SW8 verwenden und am Heizkörper mit Gabelschlüssel kontern.

Achtung: Die Gewindetiefe beträgt max. 5 mm (0,2"). Ein längeres Gewinde führt zur Zerstörung des Heizkörpers.

Achtung: Bei Verwendung von Stickstoff für ausreichende Raumbelüftung sorgen (Nur bei Geräten mit externer Druckluftversorgung).

Ersatzheißluftkolben sind justiert und können ohne Nachjustierung angeschlossen werden.

Zur Überprüfung der Heißlufttemperatur wird die Verwendung einer speziellen Meßdüse (005 87 278 08) empfohlen, durch die ein Mantelthermoelement \varnothing 0,5 mm kontaktiert werden kann.

Achtung: Für andere, von der Betriebsanleitung abweichende Verwendung sowie bei eigenmächtiger Veränderung wird von Seiten des Herstellers keine Haftung übernommen.

Achtung: Keine Arbeiten an unter Spannung stehenden Teilen durchführen. (Antistatische Kunststoffe setzen die Isoliereigenschaften herab)

Achtung: Die Betriebsanleitung des verwendeten Steuergerätes ist zu dieser Betriebsanleitung ergänzend gültig.

Lieferumfang

Heißgaspencil 24 V, 100 W	5 27 115 99
KH-Ablage	5 15 027 99
Düse 1,2 mm \varnothing	5 87 270 59
Steckschlüssel SW8	5 87 488 61

Technische Änderungen vorbehalten!

Description

F

Fer à air chaud de 100 W avec interrupteur au doigt intégré, convient pour souder et des-souder des modules à montage en surface. Un large programme de buses le rend d'usage universel.

Le flux d'air est commandé à l'aide de l'interrupteur au doigt intégré dans la poignée. L'air chaud sortant est exempt de charges statiques. Le flexible et le manche sont d'exécution antistatique. La régulation de température de l'air chaud peut être réglée avec l'appareil de commande utilisé entre 50°C et 550°C.

Données techniques:

Puissance de chauffage:	100 W
Tension de chauffage:	24 V AC
Débit d'air max.:	10 l / min
Plage de température:	50°C – 550°C
Précision:	+/- 30 °C

Mise en service

Vérifier que l'appareil de commande est débranché. Placer le fer à air chaud dans le support. Insérer la fiche de raccordement électrique dans la douille de raccordement à 7 pôles de l'appareil de commande et verrouiller. Glisser le flexible sur l'embout "AIR" de l'appareil de commande. Brancher l'appareil et régler la température et le débit d'air.

Attention: Ne pas diriger le fer à air chaud vers des personnes ou des objets inflammables. Toujours replacer le fer à air chaud dans son support d'origine lorsqu'il n'est pas utilisé.

Compensation de potentiel

Le pistolet à air chaud est équipé d'une compensation de potentiel, qui peut être branchée suivant le mode d'emploi de l'appareil de commande utilisé.

Indications concernant la technique de soudage

Les buses à air chaud sont vissées dans l'élément chauffant. Pour changer la buse, utiliser la clé à douille SW8 et bloquer avec une clé à mâchoires sur l'élément chauffant.

Attention: La profondeur de filetage est au max. de 5 mm (0,2"). Un filetage plus long provoque la destruction de l'élément chauffant.

Attention: En cas d'utilisation d'azote, veiller à une ventilation suffisante du local (Uniquement pour appareils avec alimentation externe en air)

Les fers à air de rechange sont ajustés et peuvent être raccordés sans réglage.

Pour vérifier la température de l'air chaud, on recommande l'utilisation d'une buse de mesure spéciale (005 8727808), à travers laquelle un thermoélément \varnothing 0,5 mm sous gaine peut être mis en contact.

Attention: Le fabricant décline toute responsabilité en cas de toute autre utilisation s'écartant du mode d'emploi ainsi que de modification arbitraire.

Attention: Ne pas effectuer de travaux sur des pièces sous tension. (Les matières plastiques antistatiques diminuent les caractéristiques d'isolation)

Attention: Le mode d'emploi de l'appareil de commande utilisé est valable à titre de complément à ce mode d'emploi.

Etendue de la livraison

Fer à air chaud	5 27 115 99
Support KH	5 15 027 99
Buse 1,2 mm \varnothing	5 87 270 59
Clé hexagonale SW8	5 87 488 61

Sous réserve de modifications techniques!

Descrizione

Stilo ad aria calda da 100 W con micro-interruttore integrato, idoneo per la saldatura e la dissaldatura di componentia montaggio superficiale. Un'ampia gamma di ugelli lo rende utilizzabile per applicazioni universali. Tramite il micro-interruttore integrato nell'impugnatura viene controllata la portata dell'aria. L'aria calda eiettata è libera da cariche elettrostatiche. Il tubo e l'impugnatura sono in materiale antistatico. L'aria calda a temperatura regolabile può essere impostata con la centralina tra 50°C e 550°C.

Dati tecnici:

Potenza di riscaldamento:	100 W
Tensione di riscaldamento:	24 V AC
Portata d'aria max.:	10 l / min.
Campo di temperatura:	50°C – 550°C
Precisione:	+/- 30 °C

Messa in opera

Assicurarsi che la centralina sia spenta. Riporre lo stilo ad aria calda nel supporto di sicurezza. Inserire il connettore elettrico nella boccola a 7 poli della centralina e bloccarlo in posizione. Infilare la tubazione sul nipplo "AIR" della centralina. Accendere l'apparecchio e regolare la temperatura e la portata.

Attenzione: non puntare lo stilo ad aria calda su persone o su oggetti infiammabili. Stili ad aria calda inutilizzati devono essere sempre risosti nei supporti originali.

Compensazione del potenziale

Lo stilo ad aria calda è dotato di un cavo per la compensazione del potenziale che può essere collegato come descritto nelle istruzioni d'uso della centralina utilizzata.

I

Indicazioni per la saldatura

Gli ugelli ad aria calda sono avvitati nell'elemento di riscaldamento. Per sostituirli usare una chiave cilindrica di grandezza 8 contrapponendovi sull'elemento di riscaldamento una chiave a forchetta.

Attenzione: la profondità della filettatura è di max. 5 mm (0,2"). Un filetto più lungo danneggia l'elemento di riscaldamento

Attenzione: Se si usa azoto fare in modo che l'ambiente sia ben aerato (solo in apparecchi con alimentazione di aria compressa esterna)

Stili ad aria calda di ricambio sono tarati e possono essere collegati senza necessità di regolazione.

Per controllare la temperatura dell'aria calda si raccomanda di usare uno speciale ugello di misurazione (0058727808) tramite il quale può essere collegata una termocoppia da \varnothing 0,5 mm.

Attenzione: Il costruttore non risponde per applicazioni differenti da quelle descritte nelle istruzioni d'uso e in caso di modifiche di propria iniziativa.

Attenzione: Non eseguire interventi su pezzi sotto tensione. (materiali sintetici anti-statici riducono le caratteristiche isolanti)

Attenzione: Le presenti istruzioni d'uso vengono integrate dalle istruzioni d'uso della centralina utilizzata

Composto da:

Stilo ad aria calda HGP	5 27 115 99
Supporto	5 15 027 99
Ugello diametro 1,2 mm \varnothing	5 87 270 59
Chiave a forcella SW8	5 87 488 61

Con riserva di modifiche tecniche!

Description



100 W hot air soldering tool with integrated finger switch, suitable for soldering and desoldering surface mounted components. A wide range of nozzles makes the tool of universal application.

The air flow is controlled using the finger switch integrated in the handle. The hot air flowing out of the soldering tool is free of static charges. Hose and handle are of anti-static design. The temperature-regulated hot air can be set to between 50°C and 550°C using the control unit employed.

Technical Data:

Heater rating:	100 W
Heater voltage:	24 V AC
Max. air flow rate:	10 l / min.
Temperature range:	50°C – 550°C
Precision:	+/- 30 °C

Placing in Operation

Ensure that the control unit is switched off. Place the hot air pencil in the safety stand. Plug the electrical connector into the 7-pole connecting socket on the control unit and lock. Slide the hose onto the „AIR“ nipple on the control unit. Switch on unit and set temperature and air flow rate.

Attention: Do not point the hot air soldering tool at persons or flammable objects. Always place the hot air soldering tool in the safety stand when not in use.

Equipotential Bonding

The hot air soldering tool is equipped with an equipotential bonding wire that can be configured as per the operating instructions for the control unit used.

Soldering Notes

The hot air nozzles are screwed into the heater element. To change the nozzle use the 8 AF socket spanner and lock the heater element using open-ended spanner.

Attention: The thread depth is max. 5 mm (0.2"). A longer thread will cause irreparable damage to the heater element

Attention: In case of usage of nitrogen, ensure adequate ventilation (Only on units with external compressed air supply)

Replacement hot air tools are supplied adjusted and can be connected without further adjustment.

To check the temperature of the hot air, it is recommended to use a special measuring nozzle (0058727808) through which a sheathed thermocouple \varnothing 0.5mm can be connected.

Attention: For usage other than that given in the operating instructions as well as unauthorised modification, no liability is accepted by the manufacturer.

Attention: Do not work on live parts. (Anti-static plastics reduce the insulation characteristics)

Attention: The operating instructions for the control unit used are also applicable in addition to these operating instructions

Items Supplied

Hot Gas Pencil	5 27 115 99
KH-holder	5 15 027 99
Nozzle 1,2 mm \varnothing	5 87 270 59
Socket spanner SW8	5 87 488 61

Subject to technical change without notice!

Açıklama

Parmak şalter entegre edilmiş 100 W sıcak hava havyası, dış yüzeylere monte edilmiş yapı elemanların lehimlenmesi ve lehiminin sökülmesi için uygundur. Geniş bir meme programı onu üniversal olarak kullanılabilir yapar.

Sapa entegre edilmiş parmak şalteri ile hava geçişine kumanda edilir. Dışarı püsküren havada statik yüklenme yoktur. Hortum ve sapı antistatik olarak yapılmıştır. Sıcaklık ayarlamalı sıcak hava, kullanılan kumanda cihazı ile 50°C ile 550°C arasında ayarlanabilir.

Teknik veriler:

Isıtma gücü:	100 W
Isıtma gerilimi:	24 V AC
Maks. hava miktarı:	10 l/dak
Sıcaklık bölgesi:	50°C-550°C
Hassasiyet:	+/- 30°C

İlk kullanım:

Kumanda cihazının kapatılmış durumda olmasını güvenceye alın. Sıcak hava çubuğunu emniyetli göze koyun. Elektrik bağlantı soketini kumanda cihazının 7 kutuplu bağlantı prizine takın ve kilitleyin. Hortumu kumanda cihazının "AIR" ("HAVA") nipeline takın. Cihazı açın, sıcaklığı ve hava miktarını ayarlayın.

Dikkat: Sıcak hava havyasını kişilere ve yanmakta olan nesnelere doğru doğrultmayın. Kullanılmayan sıcak hava havyasını daima orijinal muhafazasına koyun.

Potansiyel dengeleme

Sıcak hava havyası kullanılan kumanda cihazının kullanma kılavuzuna göre devreye alınabilen bir potansiyel dengeleme kablosu ile donatılmıştır.

TR

Lehim tekniği uyarıları

Sıcak hava memeleri ısıtıcı gövdelere vidalanmışlardır. Memelerin değiştirilmesi için AA8 olan lokma anahtarını kullanın ve ısıtıcı gövdeyi ağız açık anahtarla kontrol edin.

Dikkat: Vida uzunluğu azami 5 mm (0,2")dir. Vidanın daha uzun olması ısıtıcı gövdenin arızalanmasına sebep olur.

Dikkat: Azotun kullanılması halinde çalışma mahallinde yeterli bir havalandırma sağlanmalıdır.

Yedek sıcak hava havyaları ayarlanmış olup sonradan ayarlama yapılmadan bağlanabilirler.

Sıcak havanın sıcaklığının kontrolü için, muhafazalı termo elemanın (0,5 mm vasıtasıyla temas sağlanabilen özel bir ölçüm memesinin (005 87 278 08) kullanılması tavsiye edilir.

Dikkat: Kullanma talimatına göre uygun olmayan kullanımlarda ve kendi kendine bir değişiklik yapılması halinde üretici tarafından hiçbir sorumluluk kabul edilmez.

Dikkat: Gerilim altında bulunan parçalarla işlem uygulamayın. (Antistatik plastikler izolasyon özelliklerini azaltırlar)















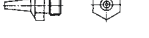

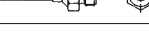

Dikkat: Kullanılan kumanda cihazının kullanma kılavuzu, bu kullanma kılavuzunun eki olarak geçerlidir.

Sevkiyat kapsamı





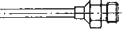















Isıtıcı gaz çubuğu 24 V, 100 W	5 27 115 99
KH muhafazası	5 15 027 99
Meme 1,2 mm	5 87 270 59
Lokma anahtarı, AA8	5 87 488 61

Teknik değişiklik hakkı saklıdır!









Heißluftdüsen für HAP 1

Modell	Typ	Abmessungen A x B	Best.-Nr.
F02	  Flachdüse	8,0 x 1,5	5 87 277 74
F04	  Flachdüse	10,0 x 1,5	5 87 277 73
F06	  Flachdüse	12,0 x 1,5	5 87 277 72
FD2	  Dualdüse	∅ 1,5 x 8,0	5 87 277 76
FD4	  Dualdüse	∅ 1,5 x 10,0	5 87 277 75
R02	  Runddüse	∅ 0,8	5 87 271 16
R04	  Runddüse	∅ 1,2	5 87 270 59
R06	  Runddüse	∅ 3,0	5 87 270 60
R08	  Runddüse, gebogen	∅ 2,0	5 87 277 86
R10	  Runddüse	∅ 2,5	5 87 277 87



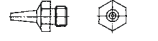

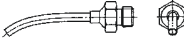





Heißluftdüsen für HAP 1

Modell	Typ	Abmessungen A x B	Best.-Nr.
2-seitig beheizt (Typ D)			
D04	  Heißluftdüse	10,5 x 10,5	5 87 277 79
D06	  Heißluftdüse	13,0 x 10,0	5 87 277 82
D08	  Heißluftdüse	15,0 x 10,0	5 87 277 81
D10	  Heißluftdüse	18,0 x 10,0	5 87 277 84
alle 4 Seiten beheizt (Typ Q)			
Q02	  Heißluftdüse	6,0 x 6,5	5 87 277 77
Q04	  Heißluftdüse	6,0 x 9,0	5 87 277 78
Q06	  Heißluftdüse	15,0 x 10,0	5 87 277 80
Q08	  Heißluftdüse	12,5 x 15,0	5 87 277 83
Q10	  Heißluftdüse	18,0 x 18,0	5 87 277 85
R01	  Meßdüse		5 87 278 08

Hot air nozzles for HAP 1

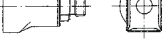
Model	Type	Dimensions A x B	Order-No.
F02	 Flat nozzle	8,0 x 1,5	5 87 277 74
F04	 Flat nozzle	10,0 x 1,5	5 87 277 73
F06	 Flat nozzle	12,0 x 1,5	5 87 277 72
FD2	 Dual nozzle	∅ 1,5 x 8,0	5 87 277 76
FD4	 Dual nozzle	∅ 1,5 x 10,0	5 87 277 75
R02	 Round nozzle	∅ 0,8	5 87 271 16
R04	 Round nozzle	∅ 1,2	5 87 270 59
R06	 Round nozzle	∅ 3,0	5 87 270 60
R08	 Round nozzle, bent	∅ 2,0	5 87 277 86
R10	 Round nozzle	∅ 2,5	5 87 277 87

Hot air nozzles for HAP 1

Model	Type	Dimensions A x B	Order-No.
2-sides heated (Type D)			
D04	 Nozzle	10,5 x 10,5	5 87 277 79
D06	 Nozzle	13,0 x 10,0	5 87 277 82
D08	 Nozzle	15,0 x 10,0	5 87 277 81
D10	 Nozzle	18,0 x 10,0	5 87 277 84
all 4 sides heated (Type Q)			
Q02	 Nozzle	6,0 x 6,5	5 87 277 77
Q04	 Nozzle	6,0 x 9,0	5 87 277 78
Q06	 Nozzle	15,0 x 10,0	5 87 277 80
Q08	 Nozzle	12,5 x 15,0	5 87 277 83
Q10	 Nozzle	18,0 x 18,0	5 87 277 85
R01	 Measuring nozzle		5 87 278 08